

Infinity Series 2015

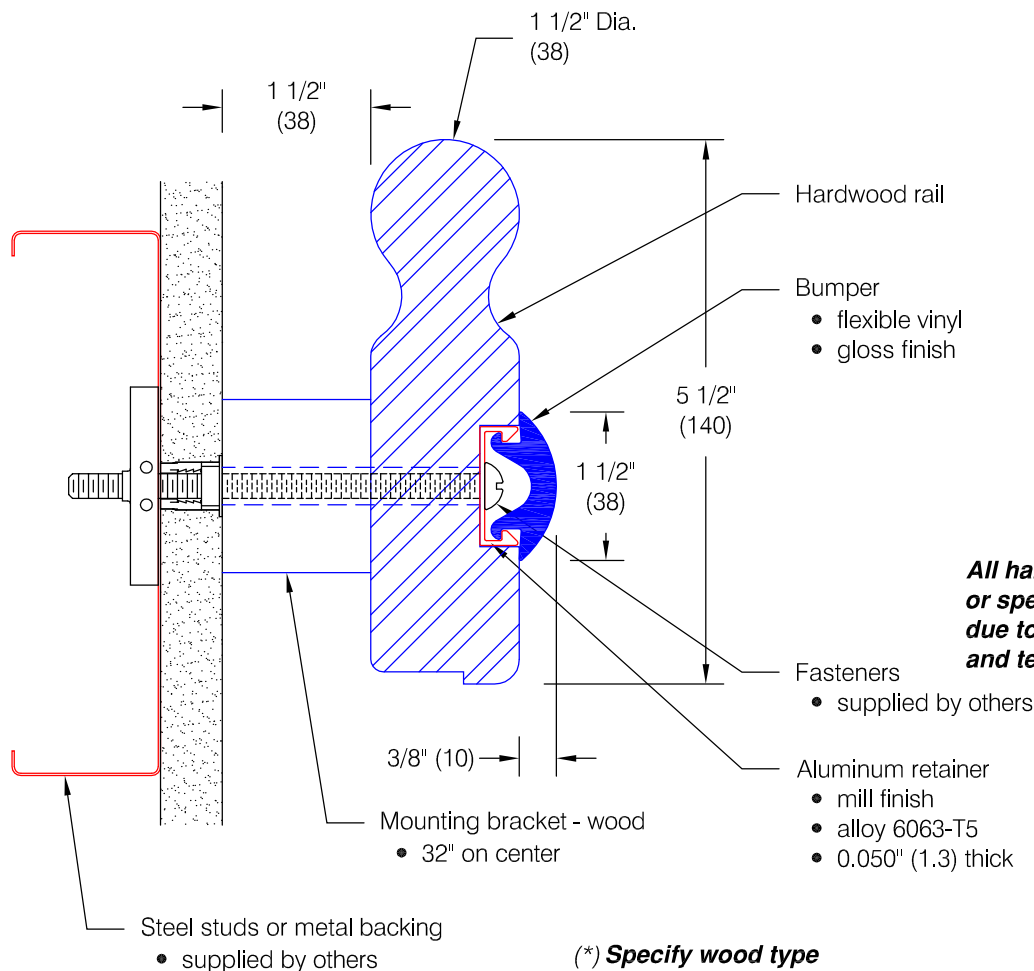

Features:

- ADA Compliant
- Factory pre-fabricated handrail system with butt joint seams where required
- Stock lengths:
Wood - random 6'-0" (1829) to 16'-0" (4877)
Aluminum and vinyl - 12'-0" (3658)

Finishes:

Vinyl Bumper

- Available in limited standard colors
- Custom colors available

Wood

- Manufacturer's standard stain colors
- Oak, maple, or ash hardwoods
- Custom woods are available
- Custom vinyl & stain colors are available

All hardwoods have their own "personality" or special characteristics. Finish may vary due to natural variations in wood color, grain and texture.

(* Specify wood type

- A - Ash
- M - Maple
- O - Oak

