

# Protector Series 2180B.3

## Features:

- Prefabricated to field verified measurements
- Factory formed 3" radius wall returns and corners
- 12'-0" maximum length without butt-joints
- Corners factory formed to accommodate angles other than 90°
- Bracket standoff 3" standard (as shown) custom standoffs are available

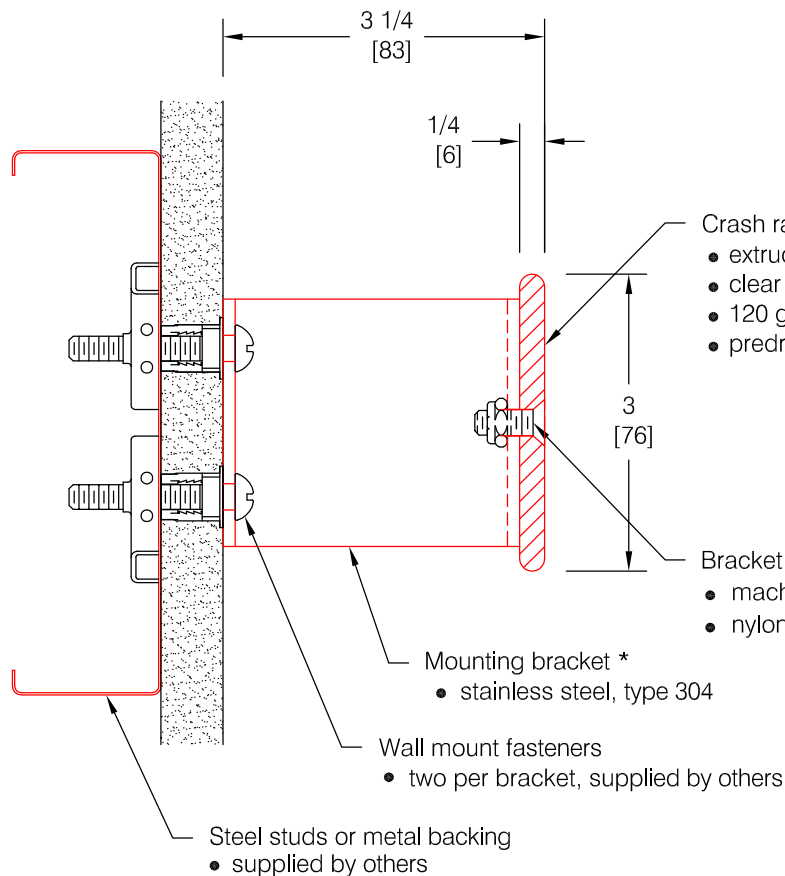

\* Nominal bracket spacing 32" on center. Actual bracket spacing will vary according to jobsite conditions. Maximum spacing not to exceed 48" (1219).

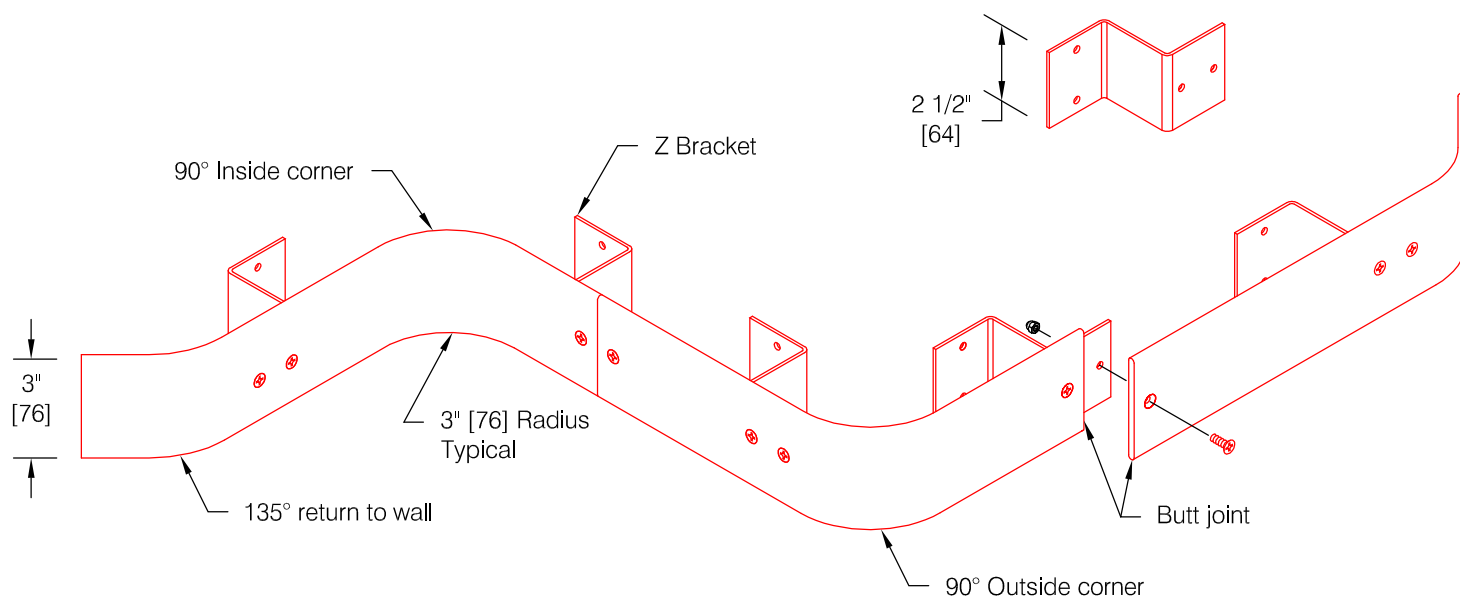

WallGuard.Com reserves the right to discontinue a design or modify an existing design without prior notice