

# Protector Series 2181.2

## Features:

- Prefabricated to field verified measurements
- Factory formed 2" radius wall returns and corners
- 12'-0" maximum length without butt-joints
- Corners factory formed to accommodate angles other than 90°
- Bracket standoff 3" standard (as shown)  
1 1/2" and 2" standoffs are available

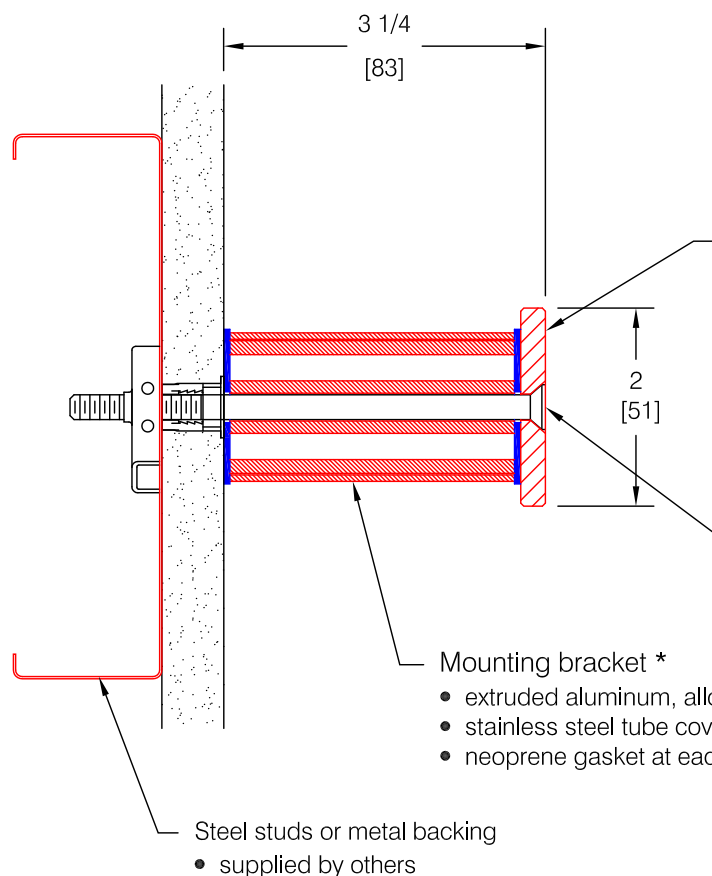

- stainless steel, type 304
  - #4 satin finish
  - chamfered edges
  - predrilled and countersunk for bracket hardware
- stainless steel machine screw, 1/4-20 x 5", flat head
  - supplied by others

- extruded aluminum, alloy 6063-T6
- stainless steel tube cover
- neoprene gasket at each end

\* Nominal bracket spacing 32" on center.  
Actual bracket spacing will vary according to jobsite conditions. Maximum spacing not to exceed 48" (1219).

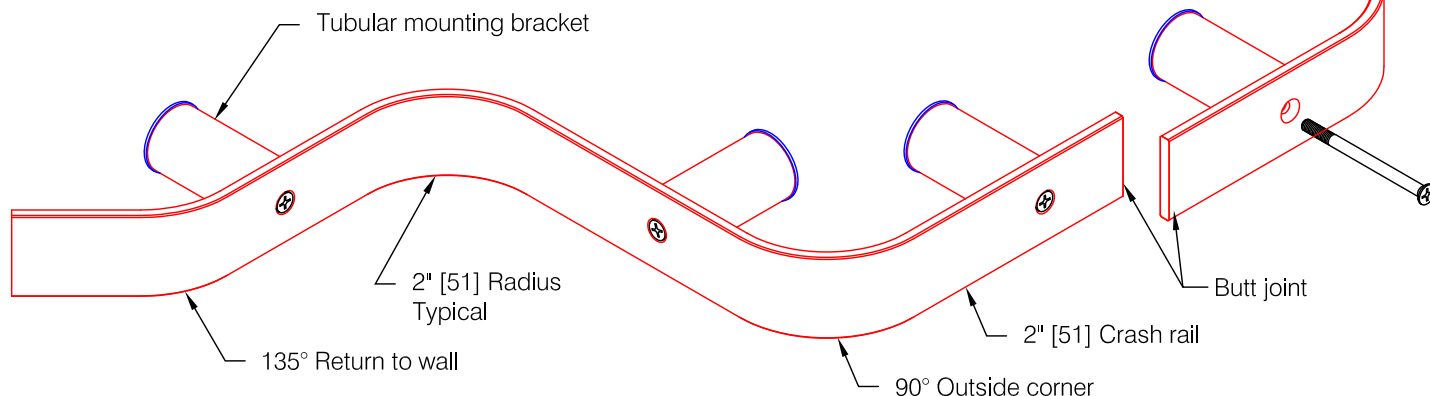
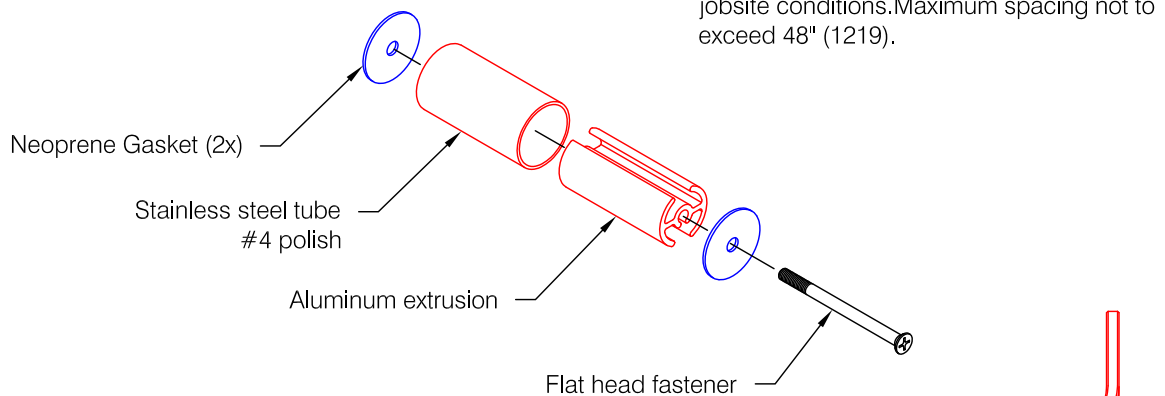

WallGuard.Com reserves the right to discontinue a design or modify an existing design without prior notice