

# Protector Series 2250 - 4"

## Features:

- Extruded EPDM rubber to RMA tolerances
- Durometer: (ASTM D-412) 70 ±5 shore A
- Tensile strength PSI: (ASTM D-412) 1,750 min.
- Elongation: (ASTM D-412) 395 min.
- Tear strength: (ASTM D-624) 229 lbs./in. Min.
- Impact resistance: (ASTM 2632) 75%
- Low temp brittleness: (ASTM D-746) -40 degrees F min.
- Ozone: (ASTM D-1171) 1142 hrs @ 102 degrees F; 20% strain - no cracks
- Deflection: (ASTM D-575) 60,000 ft./lbs. 60,000 ft./lbs. - 3" (76) with no ruptures
- Stock length: 12'-0" (3658) Black  
12'-0" (3658) Yellow  
10'-0" (3048) Gray

## Optional Features:

- Drilled for hardware:  
Approximately 12" (305) on center  
Spacing from end varies as restricted by length
- Custom drilling available
- Urethane end cap, black only

## Standard Colors:

- Black
- Gray
- Yellow

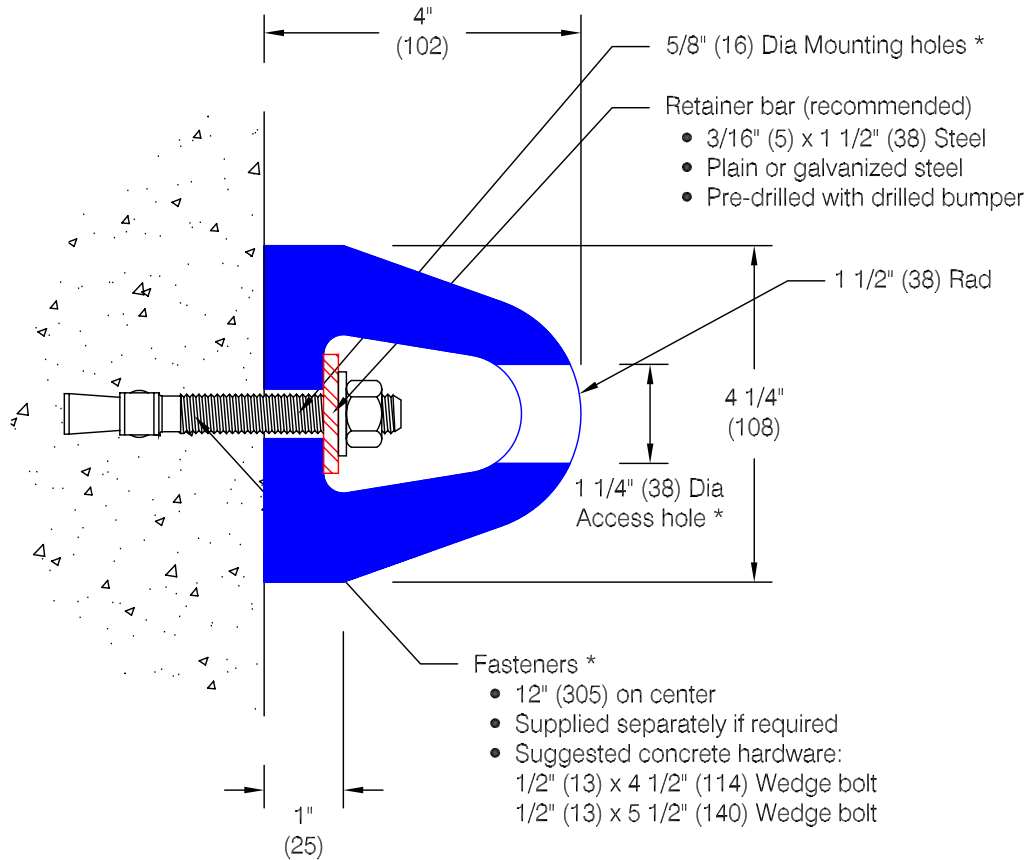

\* Standard bumper is supplied undrilled and with no mounting hardware. Hole spacing shown for bumpers 48" (1219) and longer. Contact factory for hole spacing on lengths shorter than 48" (1219).

